

B AC Motors

E.M. Brake Motor 180W (□90mm)

Motor Images

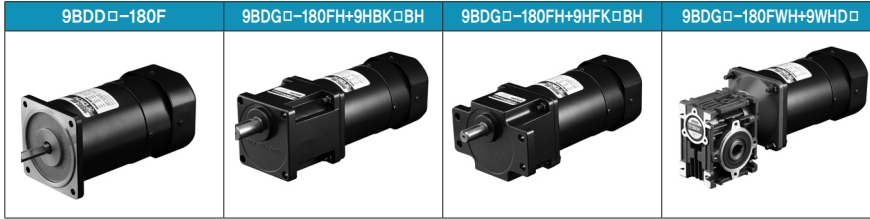

Connection Diagrams

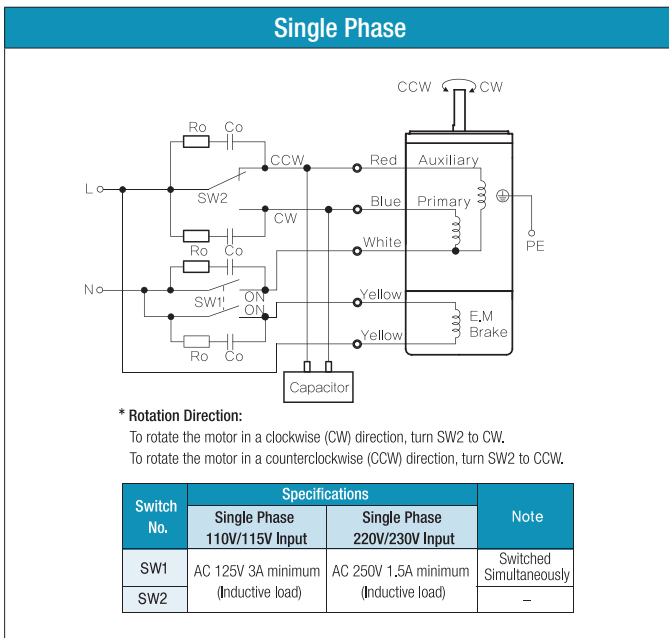

- 1) The direction of motor rotation is as viewed from the shaft end of the motor.
- 2) CW represents the clockwise direction, while CCW represents the counterclockwise direction.
- 3) SW1 operates both motor and electromagnetic brake action.
- 4) The electromagnetic brake will be released and the motor will rotate when SW1 is switched simultaneously to ON. When SW1 is switched simultaneously to OFF, the motor stops immediately with the electromagnetic brake and holds the load.
- 5) If you wish to release the brake while the motor is stopped, apply voltage between the two brake lead wires (yellow).
- 6) Ro and Co indicate CR circuit for surge suppression. [Ro=5~200Ω, Co=0.1~0.2μF, 200WV (400VW)]